

INTERIOR WALL SYSTEMS

5200
Series



FRAMED GLASS WALLS WITH SWINGING DOORS

LINEAR
INTERIOR SYSTEMS INC.

TABLE OF CONTENTS

1. OVERVIEW	4
2. SPECIFICATIONS	6
3. SYSTEM ELEVATIONS	8
4. SYSTEM CONNECTIONS	14
5. DOOR and HARDWARE OPTIONS	16
6. PANEL OPTIONS	20
7. SYSTEM COMPONENTS	22
8. NOTES	24

OVERVIEW

Linear Interior Glass Wall Systems bring the benefits of glass to your work place; among of which are transparency, efficiency, daylighting, versatility, space saving, and low cost of ownership.

Our systems come in a range of sleek designs and configurations, allowing you to build the system which matches your project's functional and aesthetic requirements. From the initial idea to completion; architects, contractors, and installers will find Linear to be a competent partner. We invite you to discover the wealth of individual scenarios that can be served by our Interior Glass Wall Systems. Be inspired with the intelligent solutions and design ideas for use in your own projects.

Design:

5200 Series is an economic framed glass wall system that provides the benefit of framing along with the aesthetic advantages of glass walls. Each glass panel is framed by slim type metal framing membranes, effectively dampening sound transmission and offering durability without impeding sight lines.

Applications:

5200 Series Framed Glass Wall Systems with Swinging Doors are ideal for:

- Office fronts
- Meeting rooms
- Spaces requiring flexible solutions
- Spaces accepting hinged or pivoted doors



SPECIFICATIONS

GLASS PANELS:

- **Thickness:** 6 mm
- **Material:** Laminated glass
- **Color:**
(Standard) Clear
(Optional) Transparent Gray,
Transparent Bronze, Super White or
Frosted
- **Panel width:**
(Standard) 2' (610mm), 3' (910mm), or
4' (1200mm)
(Optional) Non standard sizes
- **Panel height:**
(Standard) 7' (2130mm), 8' (2440mm),
or 9' (2740mm)
(Optional) Non standard sizes

METAL FRAMES:

- **Thickness:** 85mm overall
- **Material:** Aluminium
- **Color:** Painted matte black
- **Profile:** Extruded aluminium vertical
stiles, connectors, header and sill

DOORS:

- **Mechanism:** Swinging type doors
- **Material:**
(a) **framed glass door:** Matching the
glazed partition material, color and
thickness
(b) **Frameless glass door:** 10mm
tempered glass, matching the glazed
partition color
(c) **Wood door:** 44mm thick,
honeycomb wood panel, veneered
with laminated finish
- **Door width:**
(Standard) 3' (910mm), or 3'-2" (965mm)
- **Door height:**
(Standard) 7' (2130mm) or 8' (2440mm)



DOOR HARDWARE:

- **(a) Framed Glass Door:**
(Standard) Door will be provided with
3 hinges 4 1/2" X 4", 2 ball bearing,
deadbolt lock with cylinder, roller
catch, and pull handle
(Optional): Deadlatch lock with
leverset, and pivot hinges
- **(b) Frameless Glass Door:**
(Standard) Door will be provided
with top patch fitting, hydraulic
bottom patch fitting, and lockset with
magnetic strike
(Optional) Non-locking pull handle, or
pull handle with floor locking feature
- **(c) Wood Door:**
(Standard) Door will be provided with
3 hinges 4 1/2" X 4", 2 ball bearing, and
mortise lock with cylinder and leverset
(Optional) Different styles of leverset

SEALS

- **Material:** Silicone gasket retainer
between glass panels and metal frame
- **Color:** Gray

SOLID PANELS:

- **Aluminium Solid Panel:**
Panel is made of extruded frame,
polystyrene insulation, wood corners,
and plastic cover sheets clad with thin
aluminium layers
- **Wood solid panel:**
Panel is made of extruded frame,
polystyrene insulation, wood corners,
and wood cover sheets veneered with
laminated finish

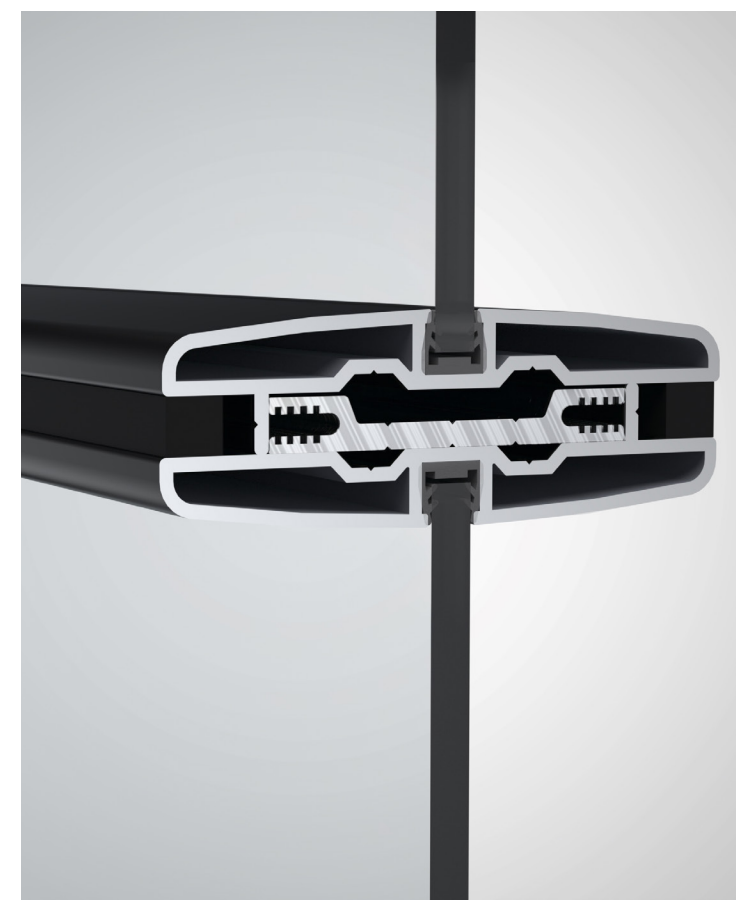

SYSTEM ELEVATIONS

The 5200 Series Aluminium Framed Glass Wall System comes in standard modular assemblies that are categorized based on height (7ft, 8ft and 9ft) and layout (full panel, half panels, horizontal panels and quarter panels). Showcased are the readily available system elevations to select from based on your project requirements. However, other non-standard assemblies and sizes are also available.



7 Feet Height Panel Systems with Swinging Door

Systems are built around the standard door size which is 3ft (36") x 7ft (84"). Standard length of the system is shown below in 7ft, 11ft and 15ft.

Full Panel System

Nominal Height: 7ft | Nominal Width: 7ft / 11ft / 15ft

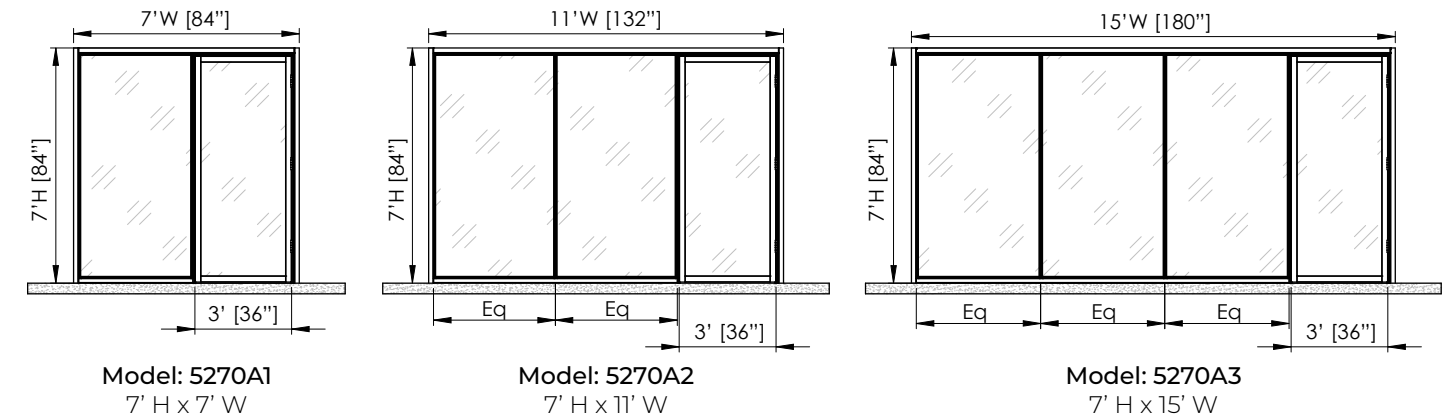

Half Panel System

Nominal Height: 7ft | Nominal Width: 7ft / 11ft / 15ft

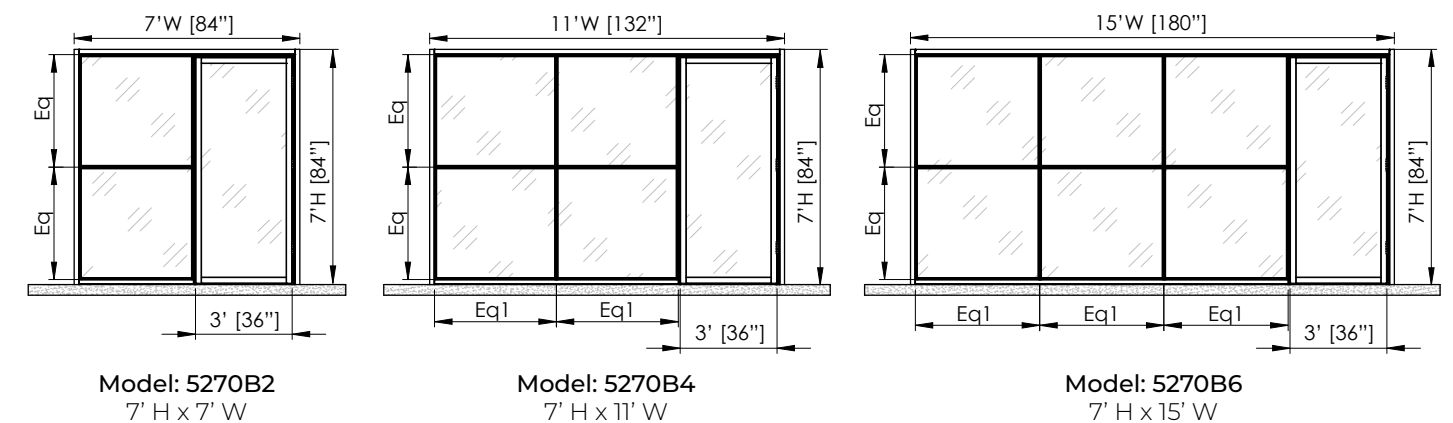

Horizontal Panel System

Nominal Height: 7ft | Nominal Width: 7ft / 10ft

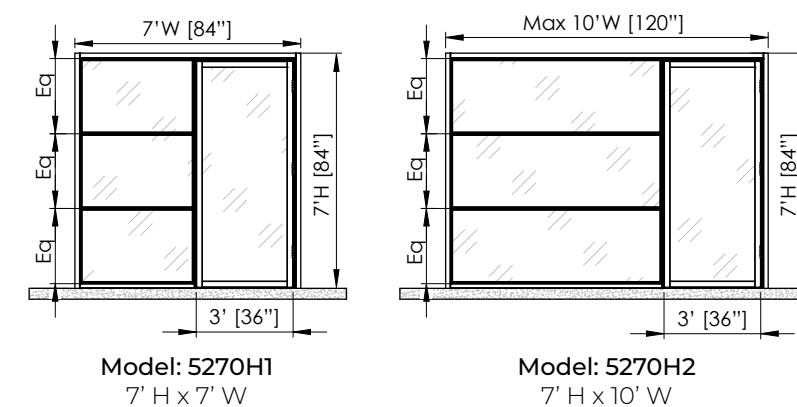

8 Feet Height Panel Systems Swinging Door and 1ft Transom

Systems are built around the standard door size which is 3ft (36") x 7ft (84"). Standard length of the system is shown below in 7ft, 11ft and 15ft.

Full Panel System

Nominal Height: 8ft | Nominal Width: 7ft / 11ft / 15ft

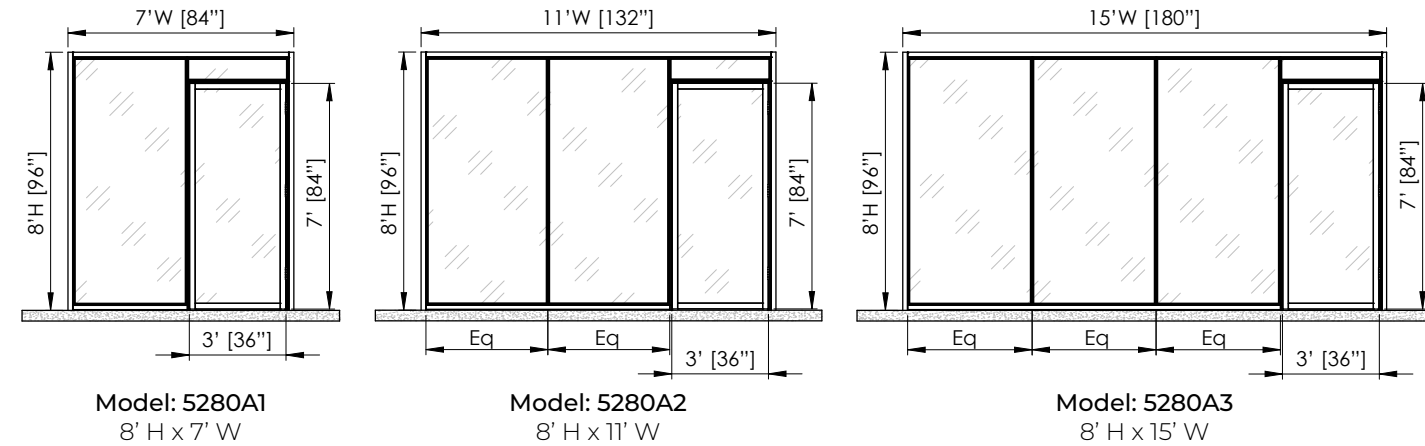

Half Panel System

Nominal Height: 8ft | Nominal Width: 7ft / 11ft / 15ft

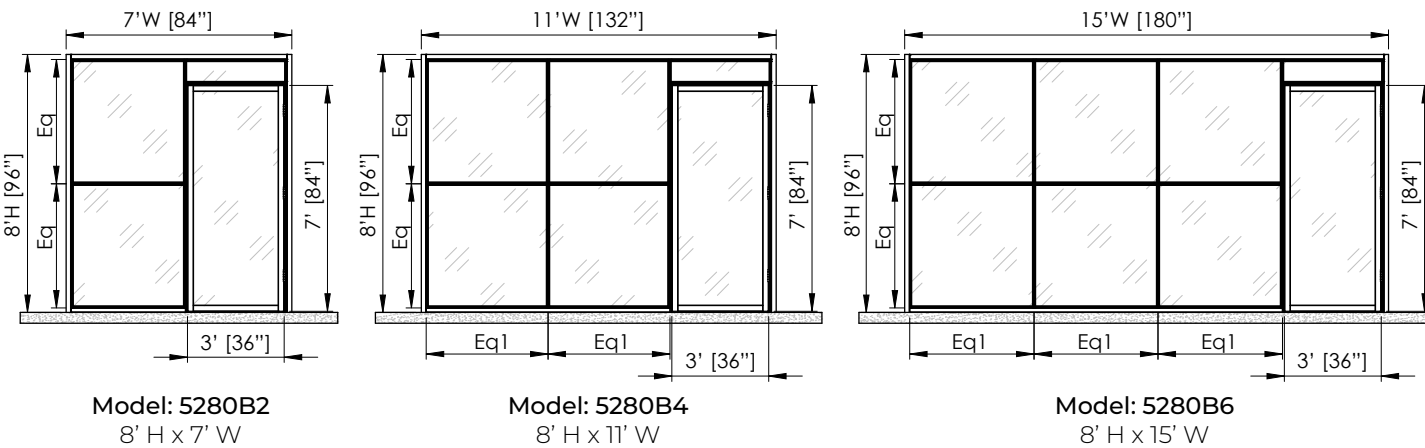

Horizontal Panel System

Nominal Height: 8ft | Nominal Width: 7ft / 10ft

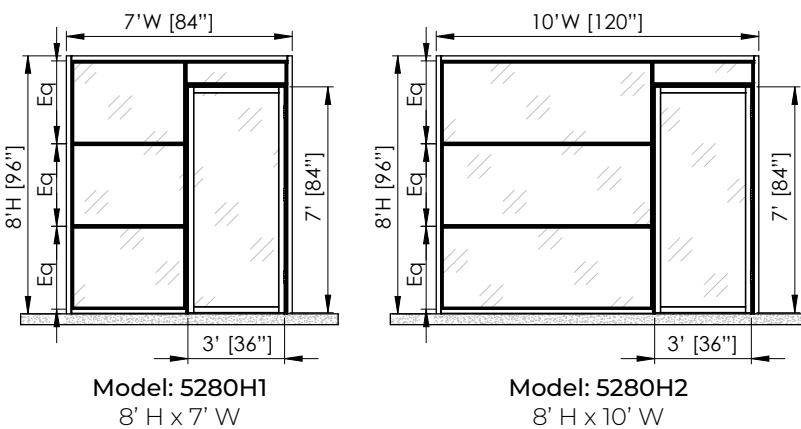

Optional:

Door can be made with 8ft Height without transom

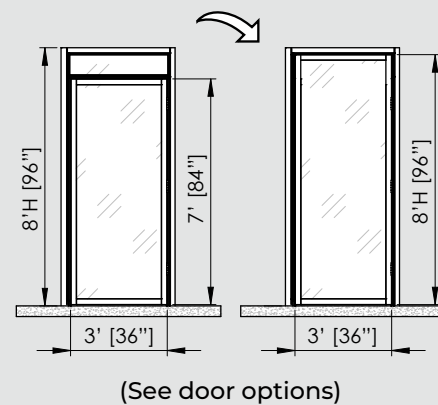

9 Feet Height Panel Systems with Swinging Door and 2ft Transom

Systems are built around the standard door size which is 3ft (36") x 7ft (84"). Standard length of the system is shown below in 7ft, 11ft and 15ft.

Full Panel System

Nominal Height: 9ft | Nominal Width: 7ft / 11ft / 15ft

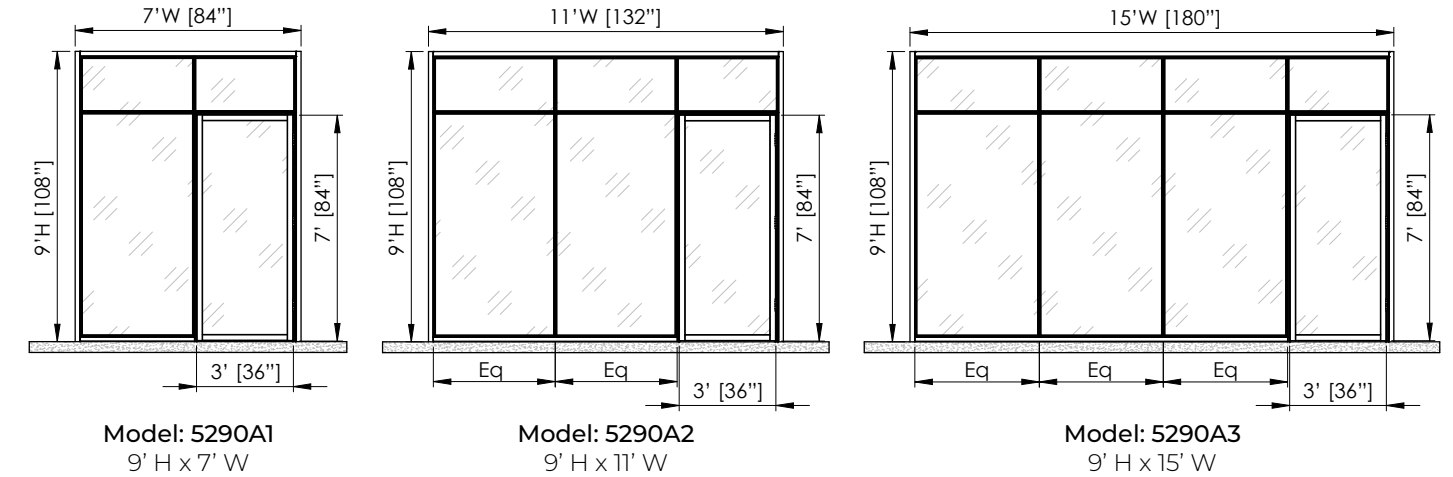

Half Panel System

Nominal Height: 9ft | Nominal Width: 7ft / 11ft / 15ft

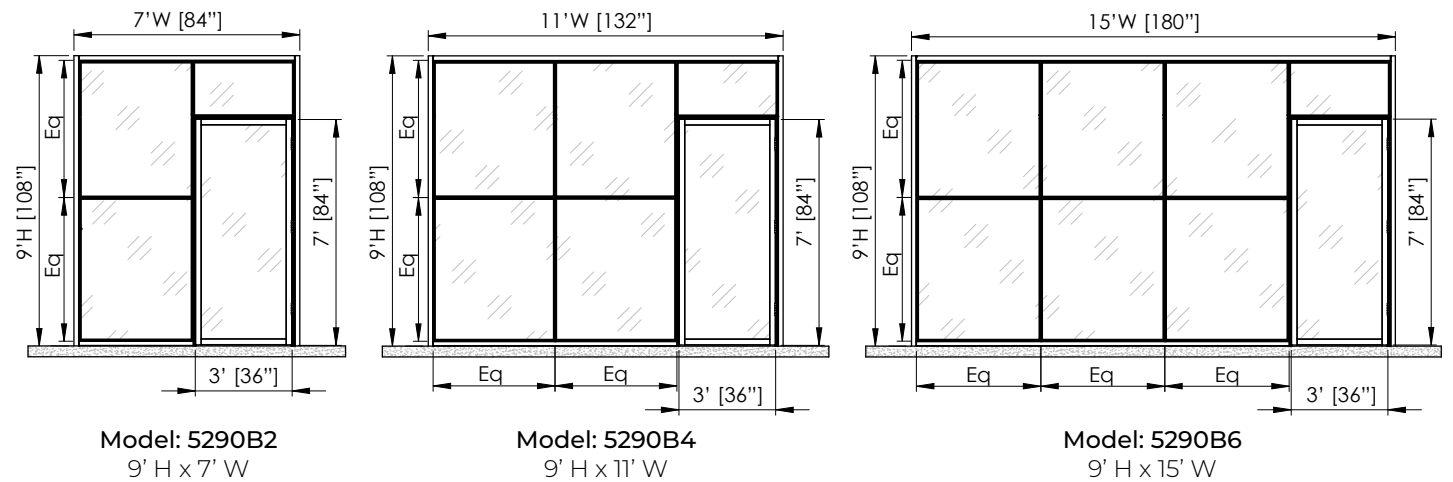

Horizontal Panel System

Nominal Height: 9ft | Nominal Width: 7ft / 10ft

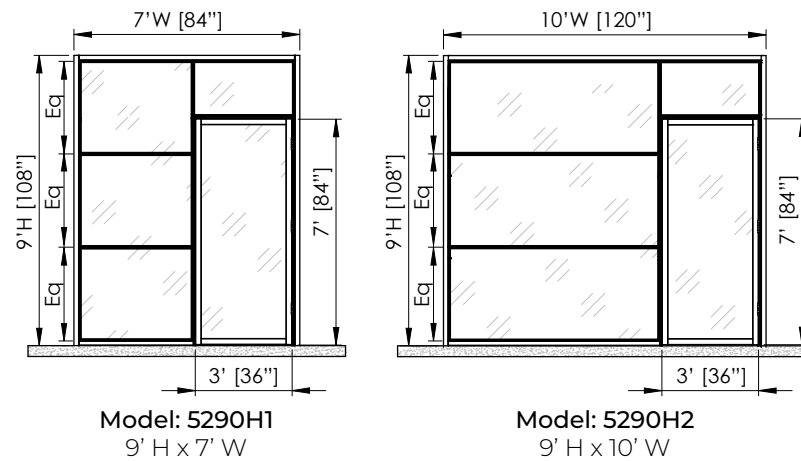

Optional:

Door can be made with 8ft Height with a 1ft transom

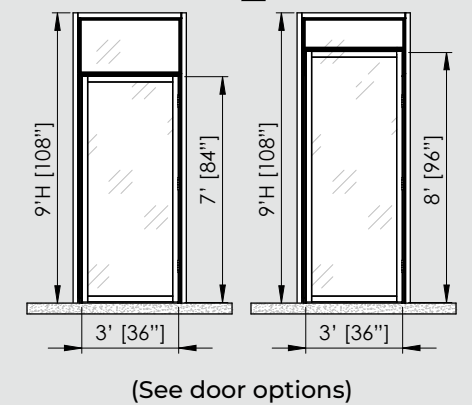

Panel Only Systems

Standard length of the system is shown below in 4ft, 8ft, 12ft and 16ft. Standard heights of the system vary from system to system.

Full Panel System

Nominal Height (H): 7ft / 8ft
Nominal Width: 4ft / 8ft / 12ft / 16ft

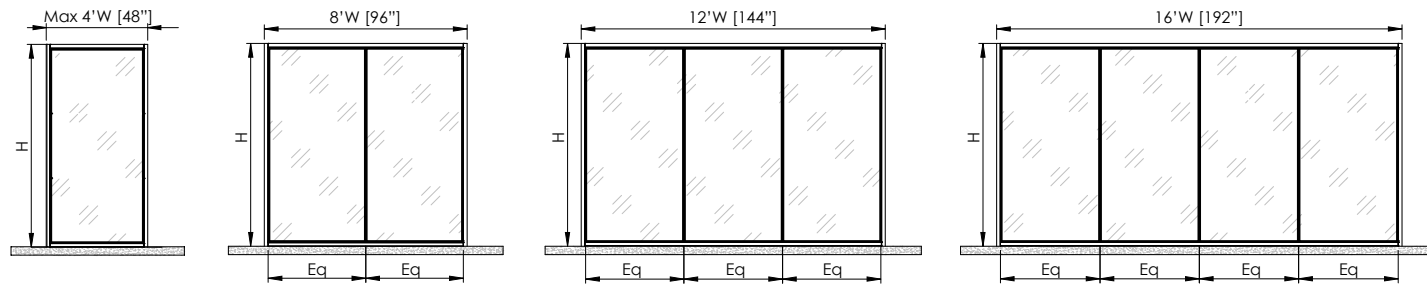

- | | | | |
|--------------------------------------|--------------------------------------|---------------------------------------|---------------------------------------|
| Model: 5270FA1
7' H x 4' W | Model: 5270FA2
7' H x 8' W | Model: 5270FA3
7' H x 12' W | Model: 5270FA4
7' H x 16' W |
| Model: 5280FA1
8' H x 4' W | Model: 5280FA2
8' H x 8' W | Model: 5280FA3
8' H x 12' W | Model: 5280FA4
8' H x 16' W |

Half Panel System

Nominal Height (H): 7ft / 8ft / 9ft
Nominal Width: 4ft / 8ft / 12ft / 16ft

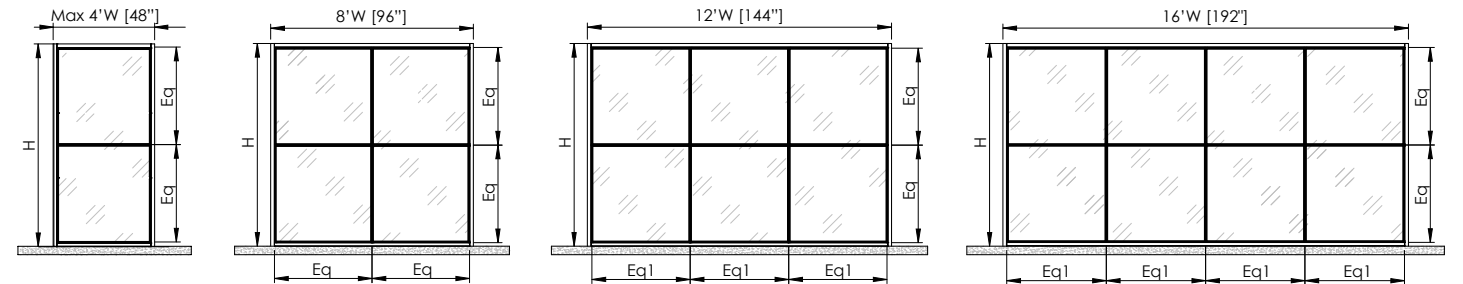

- | | | | |
|--------------------------------------|--------------------------------------|---------------------------------------|---------------------------------------|
| Model: 5270FB2
7' H x 4' W | Model: 5270FB4
7' H x 8' W | Model: 5270FB6
7' H x 12' W | Model: 5270FB8
7' H x 16' W |
| Model: 5280FB2
8' H x 4' W | Model: 5280FB4
8' H x 8' W | Model: 5280FB6
8' H x 12' W | Model: 5280FB8
8' H x 16' W |
| Model: 5290FB2
9' H x 4' W | Model: 5290FB4
9' H x 8' W | Model: 5290FB6
9' H x 12' W | Model: 5290FB8
9' H x 16' W |

Full Panel System with Transom

Nominal Height: 9ft
Nominal Width: 4ft / 8ft / 12ft / 16ft

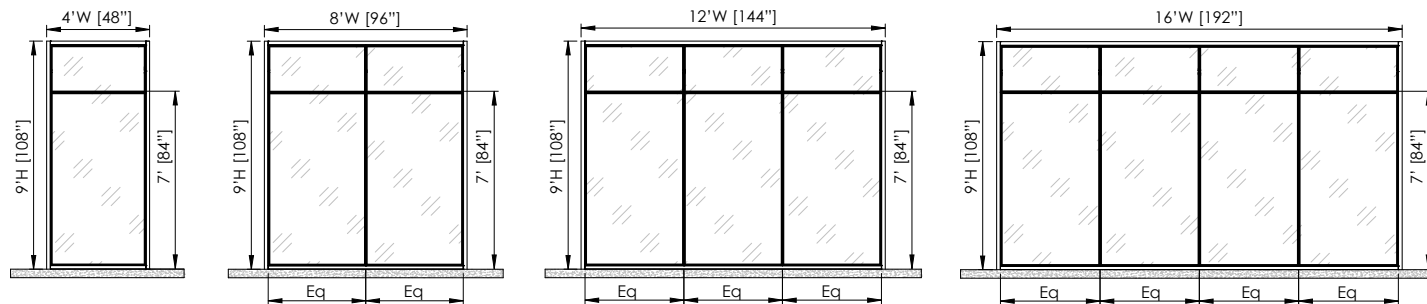

- | | | | |
|--------------------------------------|--------------------------------------|---------------------------------------|---------------------------------------|
| Model: 5290FA1
9' H x 4' W | Model: 5290FA2
9' H x 8' W | Model: 5290FA3
9' H x 12' W | Model: 5290FA4
9' H x 16' W |
|--------------------------------------|--------------------------------------|---------------------------------------|---------------------------------------|

Quarter Panel System

Nominal Height (H): 7ft / 8ft / 9ft
Nominal Width: 4ft / 8ft / 12ft / 16ft

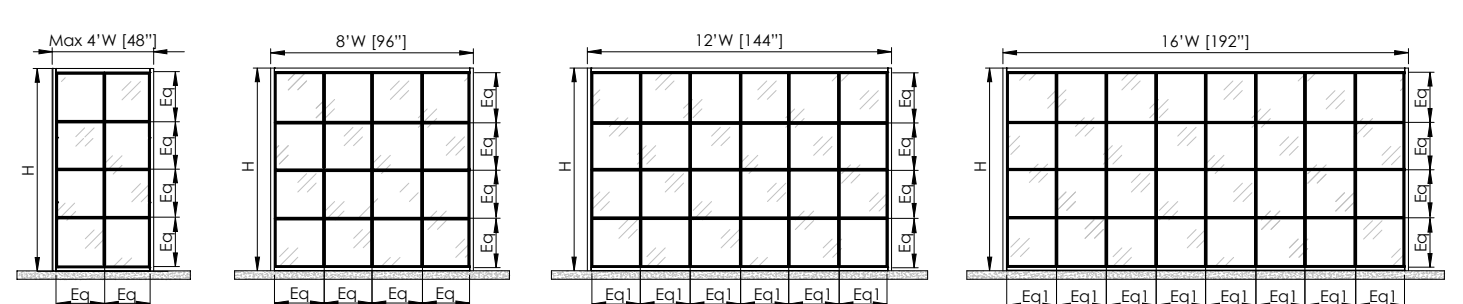

- | | | | |
|--------------------------------------|---------------------------------------|--|--|
| Model: 5270FQ8
7' H x 4' W | Model: 5270FQ16
7' H x 8' W | Model: 5270FQ24
7' H x 12' W | Model: 5270FQ36
7' H x 16' W |
| Model: 5280FQ8
8' H x 4' W | Model: 5280FQ16
8' H x 8' W | Model: 5280FQ24
8' H x 12' W | Model: 5280FQ36
8' H x 16' W |
| Model: 5290FQ8
9' H x 4' W | Model: 5290FQ16
9' H x 8' W | Model: 5290FQ24
9' H x 12' W | Model: 5290FQ36
9' H x 16' W |

Horizontal Panel System

Nominal Height: 7ft / 8ft / 9ft
Nominal Width: 4ft / 7ft

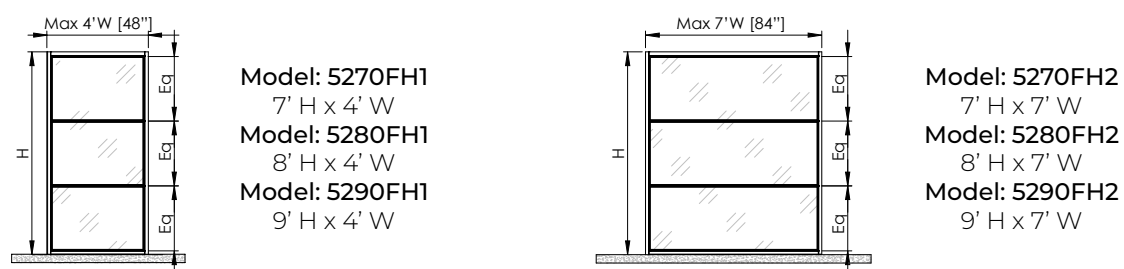

- | | |
|--------------------------------------|--------------------------------------|
| Model: 5270FH1
7' H x 4' W | Model: 5270FH2
7' H x 7' W |
| Model: 5280FH1
8' H x 4' W | Model: 5280FH2
8' H x 7' W |
| Model: 5290FH1
9' H x 4' W | Model: 5290FH2
9' H x 7' W |

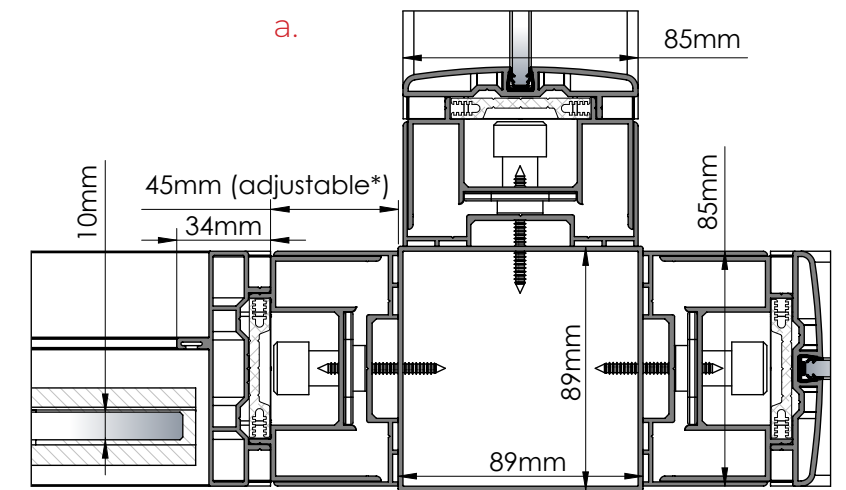
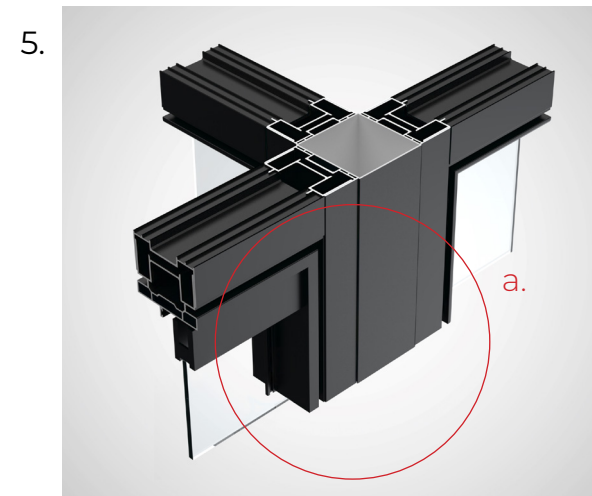
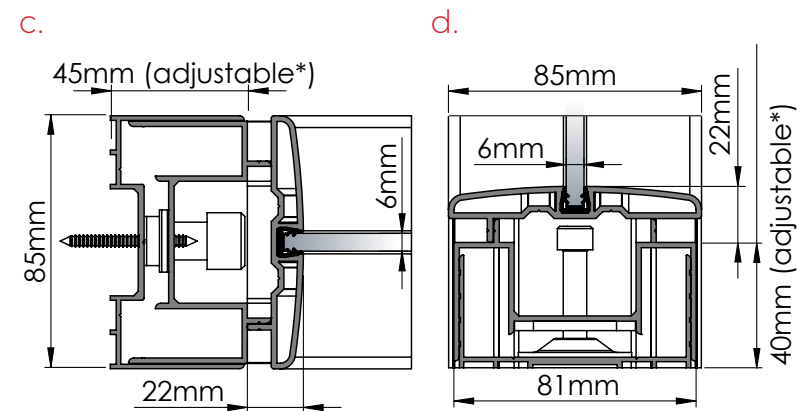
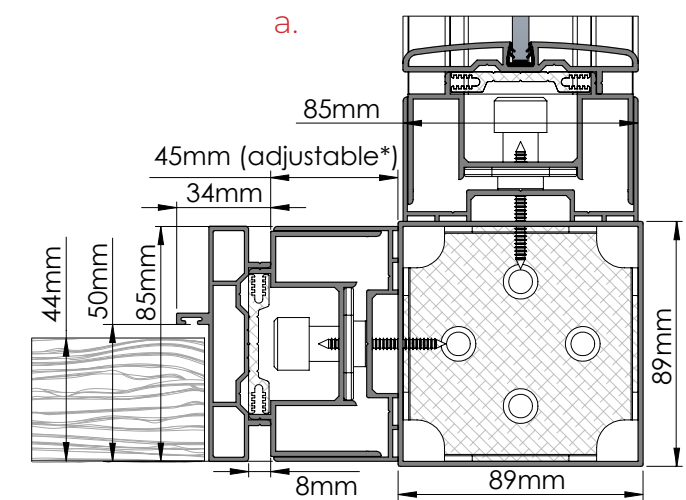
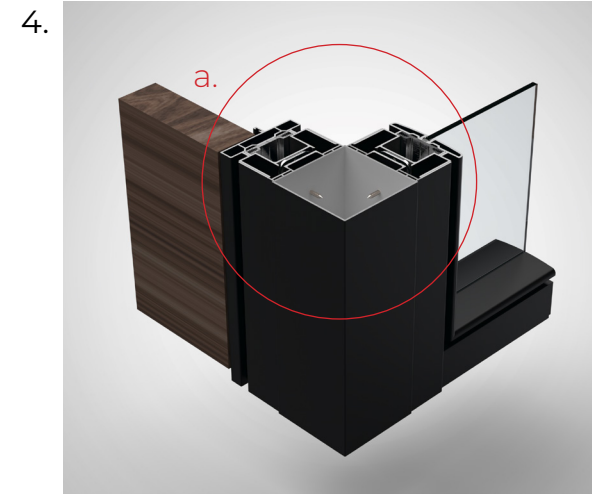
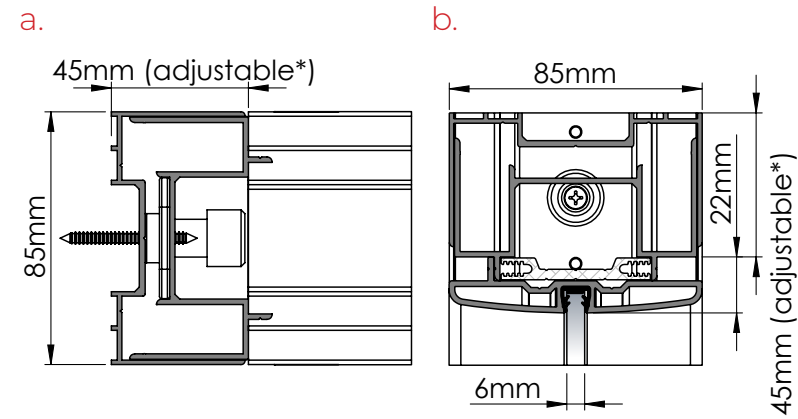
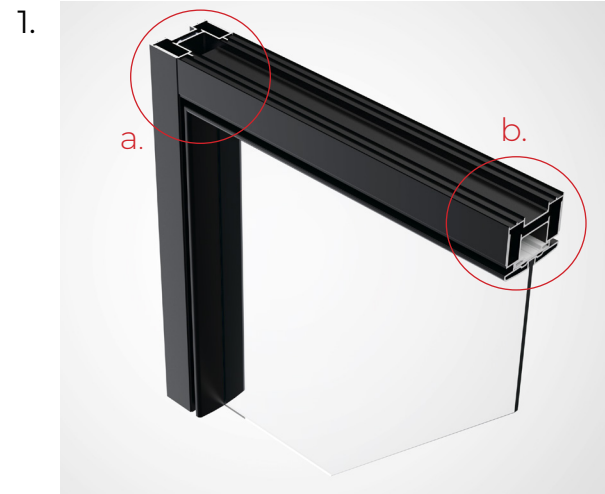

Detailed drawings of wall, floor and top starter of 5200 Series wall system. Starters are *adjustable to 8mm to ensure the system shall be installed level and square if the existing rough opening surfaces are even.

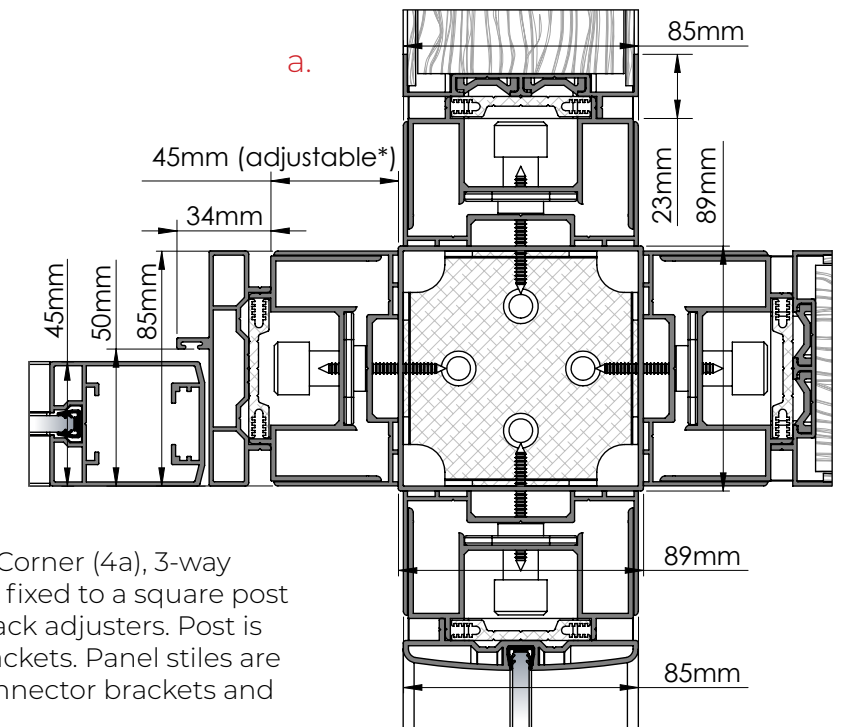
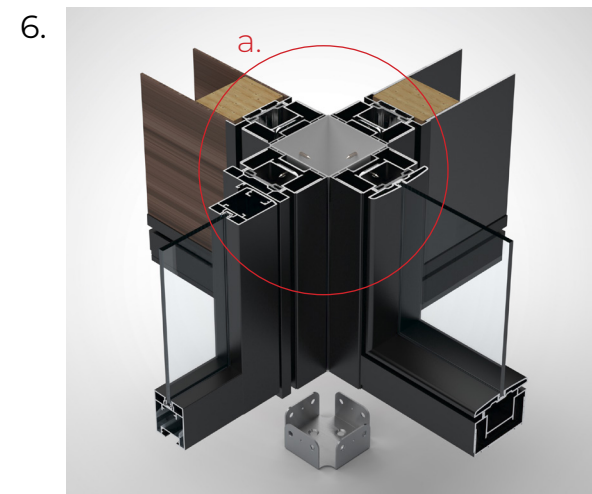
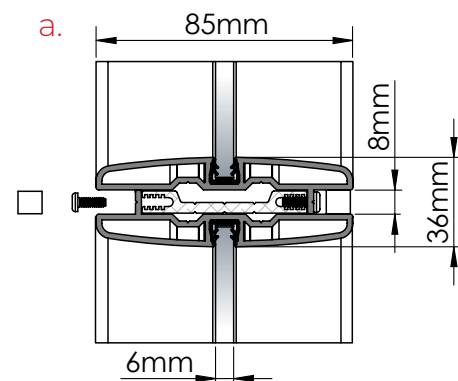
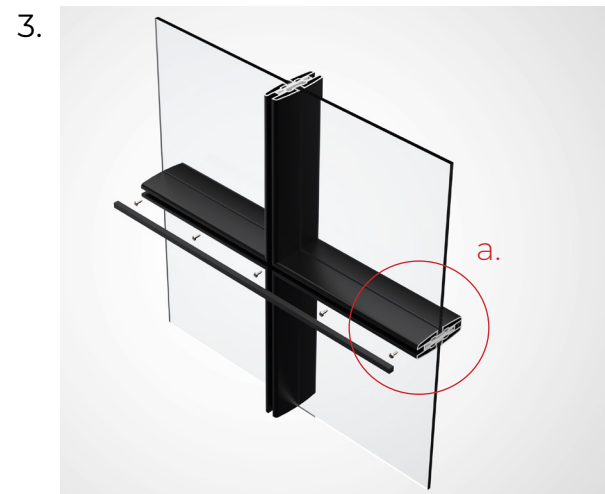

Detailed drawing of panel to panel connection. Panel stiles and rails are connected by aluminium connector brackets placed between panels to allow for secure connection points by screws. Screws are hidden behind a piece of foam gasket which provides a clean architectural finish to the system.

Different positions of system connections: Corner (4a), 3-way (5a), and 4-way (6a). Adjustable starters are fixed to a square post and shall be aligned level and square by track adjusters. Post is fixed to floor and ceiling by connecting brackets. Panel stiles are connected to the adjustable starters by connector brackets and screws.

DOOR AND HARDWARE OPTIONS

1. Aluminium Framed Glass Doors
2. Frameless Glass Doors
3. Wood Doors



1. ALUMINIUM FRAMED GLASS DOOR



Standard Door

- 6mm laminated glass and Extruded aluminium frame composed of stiles, rails and retainers
- Sizes: 36-38" W x 84" H

Door Hardware:

- 3/ea. Standard weight, 2 ball bearing, steel hinges (4.5" x 4" x 3.4mm)
- 1/ea. Roller catch
- 1/set. Deadbolt lock with cylinder
- 1/ea. Pull Handle (36" standard)

Standard Aluminium + Glass Finish:

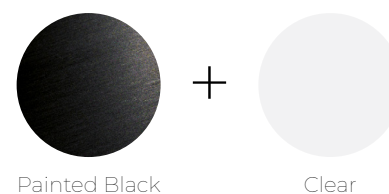

Optional Door

- Solid panel at lower part of the door
- Size: 36-38" W x Up to 96" H

Optional Door Hardware:

- 1/set. Deadlatch lock with cylinder
- 1/set. Pivot hinges
- 1/set. Various lever design options in different finishes (see catalogue for lever options)

Optional Glass Finish:

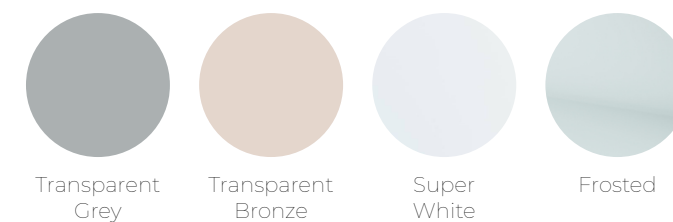

2. GLASS DOOR

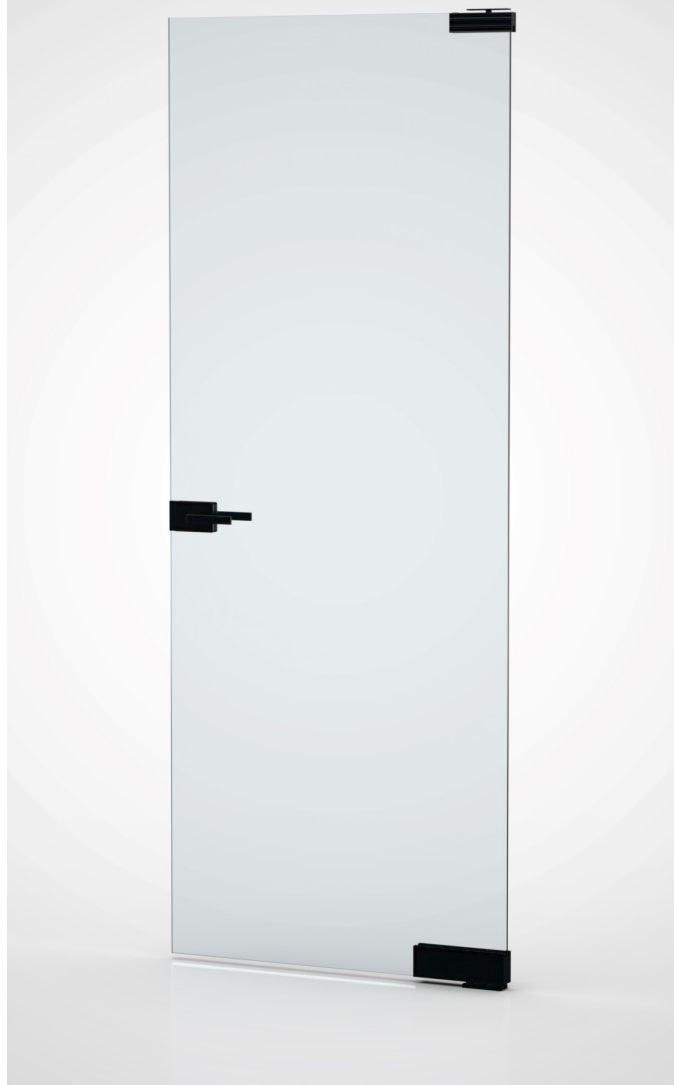

Standard Door

- 10mm Tempered glass
- Size: 36-38" W x 84" H

Standard Door Hardware:

- 1/set. Top patch fitting
- 1/ea. Hydraulic bottom patch fitting
- 1/set. Lock and Magnetic strike

Standard Glass Finish:



Clear



Optional Door

- 12mm tempered glass
- Size: 36-38" W x Up to 96" H

Optional Door Hardware:

- 1/set. Non-locking Pull Handle
- 1/set. Pull handle with locking function
- Various sizes for pull handles available

Optional Glass Finish:



Transparent Grey



Transparent Bronze



Frosted

3. WOOD DOOR



Standard Door:

- Honeycomb veneered panels with HD boards coated with laminated finish, 44mm thick
- Standard Sizes: 36-38" W x 84" H

Door Hardware:

- 3/ea. Standard weight, 2 ball bearing, steel hinges (4.5" x 4" x 3.4mm)
- 1/set. Mortise lock, Office function with cylinder
- 1/set. Levers

Standard Wood Finishes:



Bianco 48



Rovere Naturale 05



Antracite 45



Noce F 67

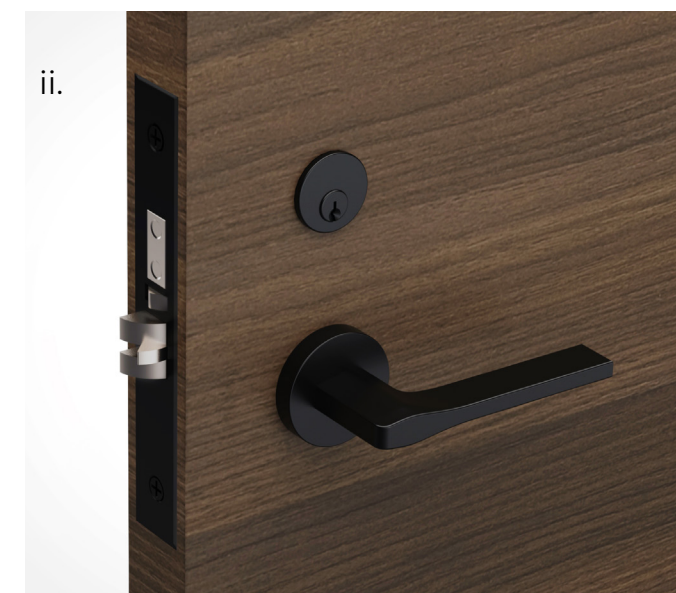

Optional Door

- Semi-solid panels with HD boards coated with laminated finish, 44mm thick
- Size: 36-38" W x Up to 96" H

Optional Door Hardware:

- 1/set. Various lever design options in different finishes (see catalogue for lever options)

PANEL OPTIONS

1. Glass Panel
2. Solid Panel - Aluminium
3. Solid Panel - Wood



1. GLASS PANEL :

Thickness: 6 mm

Material: Laminated glass (safety glass) designed to meet standard requirements for safety

Extruded aluminium frame composed of stiles and rails, factory assembled with glass and seals

Material Finish:

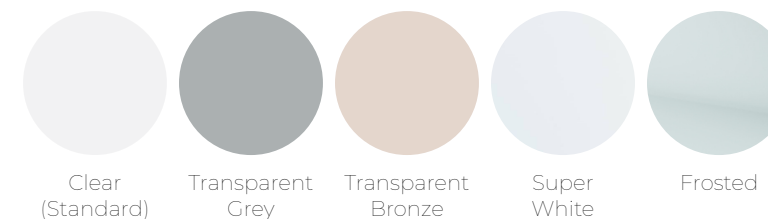

2. SOLID PANEL - ALUMINIUM :

Profile: Extruded aluminium frame, assembled with polystyrene insulation , wood structure and cover sheets

Material: Thin aluminium sheet panel

Material Finish:

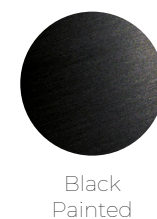

3. SOLID PANEL - WOOD :

Profile: Extruded aluminium frame, assembled with polystyrene insulation , wood structure and cover sheets

Material: Thin wood panel

Material Finish (ii):



Standard Panel Width: · 2ft [610mm]
(Glass or Solid) · 3ft [910mm]
 · 4ft [1200mm]

Standard Panel Height: · 7ft [2130mm]
(Glass or Solid) · 8ft [2440mm]
 · 9ft [2740mm]

Optional non standard sizes are also available, contact factory for more details



1. Laminated glass panel

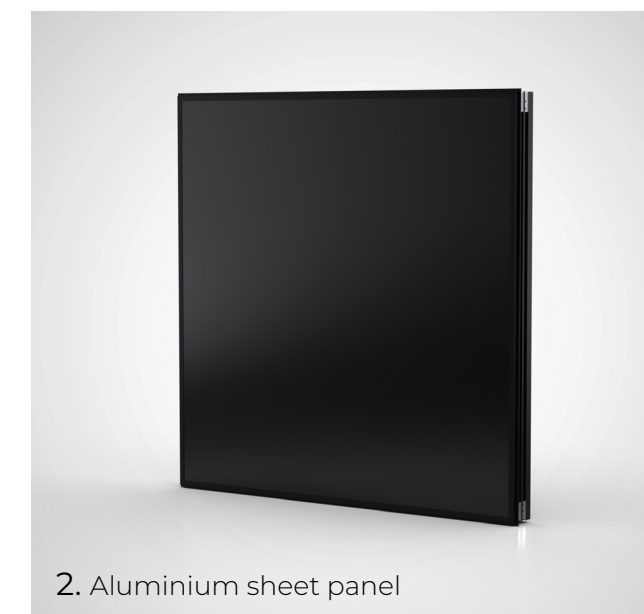

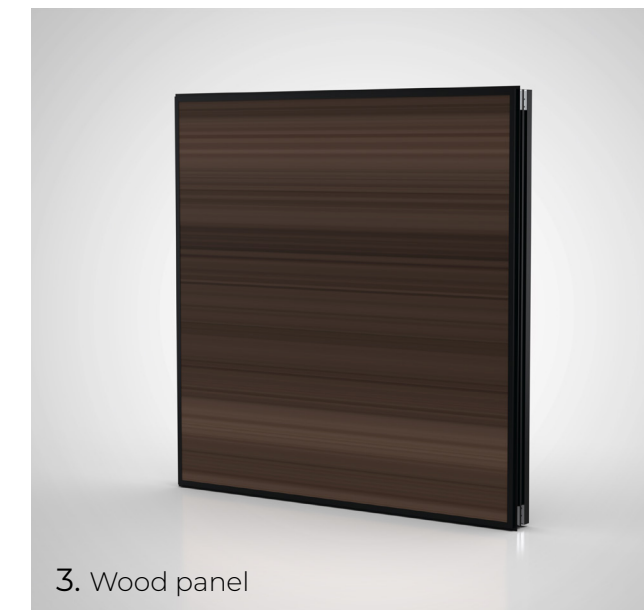

2. Aluminium sheet panel

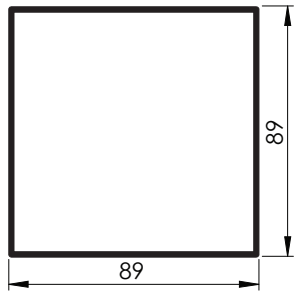
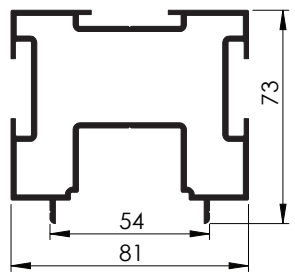
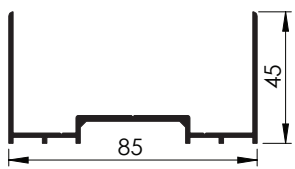
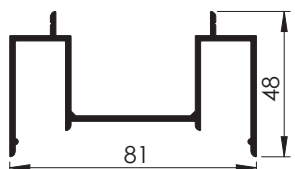
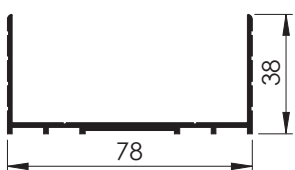
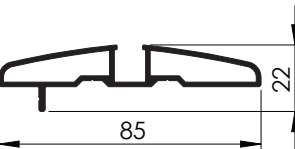
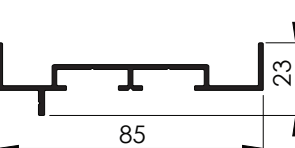

3. Wood panel

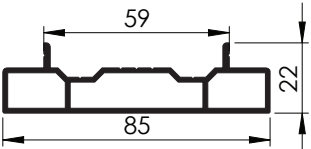
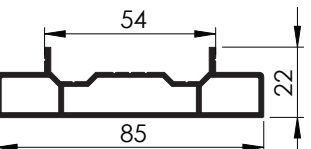
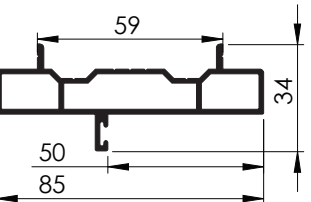
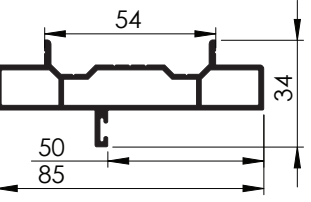
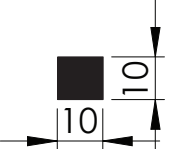
TRACKS		
1	LIN 5200-101 Wall Post	
2	LIN 5200-351 Ceiling Standalone Post	
3	LIN 5200-201 Wall Starter	
4	LIN 5200-202 Starter Cap	
5	LIN 5200-401 Floor Starter	
6	LIN 5200-601 Rail / Stile for Glass	
7	LIN 5200-603 Rail / Stile for Panels	

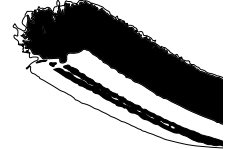
DOOR FRAME TRACKS		
8	LIN 5200-126 Door Frame (wide tab)	
9	LIN 5200-127 Door Frame	
10	LIN 5200-128 Door Frame with Stopper (wide tab)	
11	LIN 5200-129 Door Frame with Stopper	
GASKETS		
12	LIN 5200-132 Sponge Gasket	
13	LIN 5200-565 Glass Gasket	
14	LIN 207 Brush Gasket for Door Stopper	

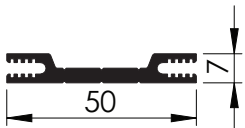
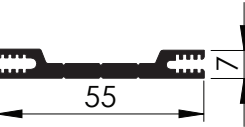
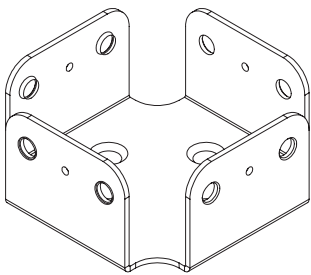
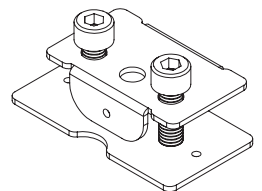
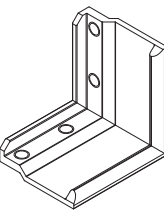
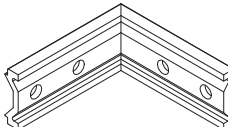
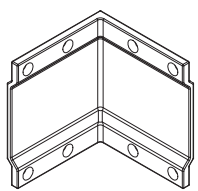
TRACK BRACKETS		
15	LIN 5200-106 Connector Bracket for Regular Tab Rails / Stiles	
16	LIN 5200-108 Connector Bracket for Wide Tab Rails / Stiles	
17	LIN 5200-354 Floor Bracket for Post 5200-101	
18	LIN 5200-355 Connecting Bracket for Ceiling Post 5200-351	
19	LIN 5200-604 Corner Bracket for Rail / Stile 5200-601	
20	LIN 5200-605 Corner Bracket for Rail / Stile 6200-602	
21	LIN 5200-606 Corner Bracket for Door Frame Tracks	

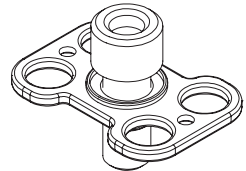
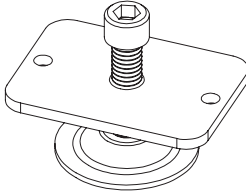
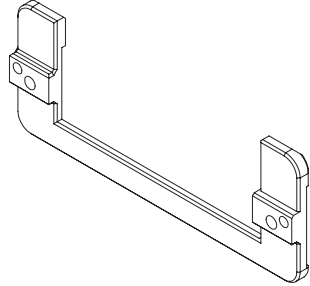
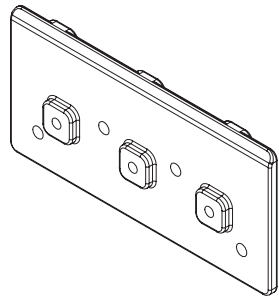
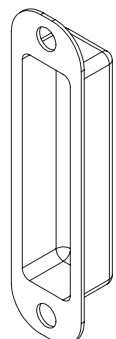
ADJUSTERS		
22	LIN 5200-502 Screw in Wall Track Adjuster	
23	LIN 5200-526 Floor Track Adjuster	
HARDWARE & HARDWARE BRACKETS		
24	LIN 5200-158 Strike and Dust Box Bracket	
25	LIN 5200-159 Hinge Plate Bracket	
26	LIN 5200-183 Dust Box	

LINEAR

INTERIOR SYSTEMS INC.

Linear Interior Systems Inc.
20 Alex Avenue
Woodbridge, ON, L4L 5X1
CANADA

Tel: +1 (905) 265-0055
Fax: +1 (905) 265-0035

www.linearinteriorsystems.com
Info@linearinteriorsystems.com